



US006983097B2

(12) **United States Patent**  
**McGlashan-Powell et al.**

(10) **Patent No.:** **US 6,983,097 B2**

(45) **Date of Patent:** **Jan. 3, 2006**

(54) **MAGNETO-OPTICAL SWITCHING  
BACKPLANE FOR PROCESSOR  
INTERCONNECTION**

(58) **Field of Classification Search** ..... 385/4,  
385/6, 14-16, 24; 398/164; 370/351, 360  
See application file for complete search history.

(75) Inventors: **Maurice McGlashan-Powell**, Mt.  
Vernon, NY (US); **Philip Charles  
Danby Hobbs**, Briarcliff Manor, NY  
(US)

(56) **References Cited**

**U.S. PATENT DOCUMENTS**

3,990,776 A \* 11/1976 Tseng et al. .... 385/6  
4,870,637 A \* 9/1989 Follett et al. .... 398/164  
5,726,788 A \* 3/1998 Fee et al. .... 398/164  
5,786,912 A \* 7/1998 Kartalopoulos ..... 398/50  
6,577,430 B1 \* 6/2003 Jin et al. .... 359/280

(73) Assignee: **International Business Machines  
Corporation**, Armonk, NY (US)

(\* ) Notice: Subject to any disclaimer, the term of this  
patent is extended or adjusted under 35  
U.S.C. 154(b) by 0 days.

\* cited by examiner

*Primary Examiner*—Rodney Bovernick  
*Assistant Examiner*—Omar Rojas

(21) Appl. No.: **10/840,846**

(74) *Attorney, Agent, or Firm*—George Sai-Halasz; Robert  
M. Trepp

(22) Filed: **May 7, 2004**

(65) **Prior Publication Data**

US 2004/0208472 A1 Oct. 21, 2004

(57) **ABSTRACT**

**Related U.S. Application Data**

A system and method are disclosed for an optical backplane in an electronic processor that comprises of a plurality of processing units. The backplane is comprising of a network of optical waveguides which can guide polarized light. Furthermore, the backplane has magneto optic routers for steering light at the vertexes of the network, and the backplane also has optical devices for operationally connecting the processing units to the network. The backplane network affords an optical interconnection amongst all of the processing units.

(62) Division of application No. 10/073,450, filed on Feb.  
11, 2002, now Pat. No. 6,816,637.

(51) **Int. Cl.**  
**G02B 6/35** (2006.01)  
**G02B 6/28** (2006.01)  
**G02F 1/295** (2006.01)

(52) **U.S. Cl.** ..... **385/147; 385/14; 385/6;**  
**385/16; 385/24; 398/82**

**5 Claims, 7 Drawing Sheets**

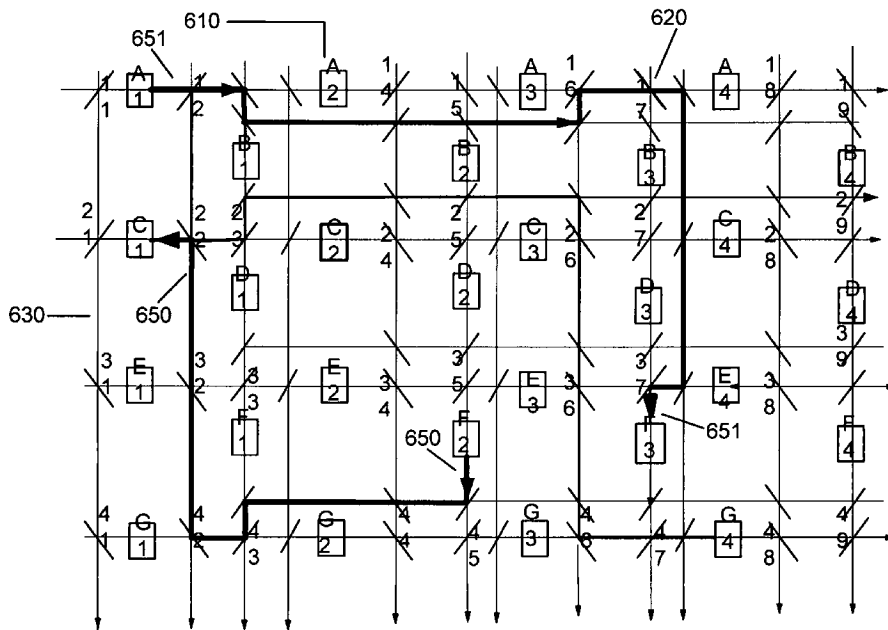

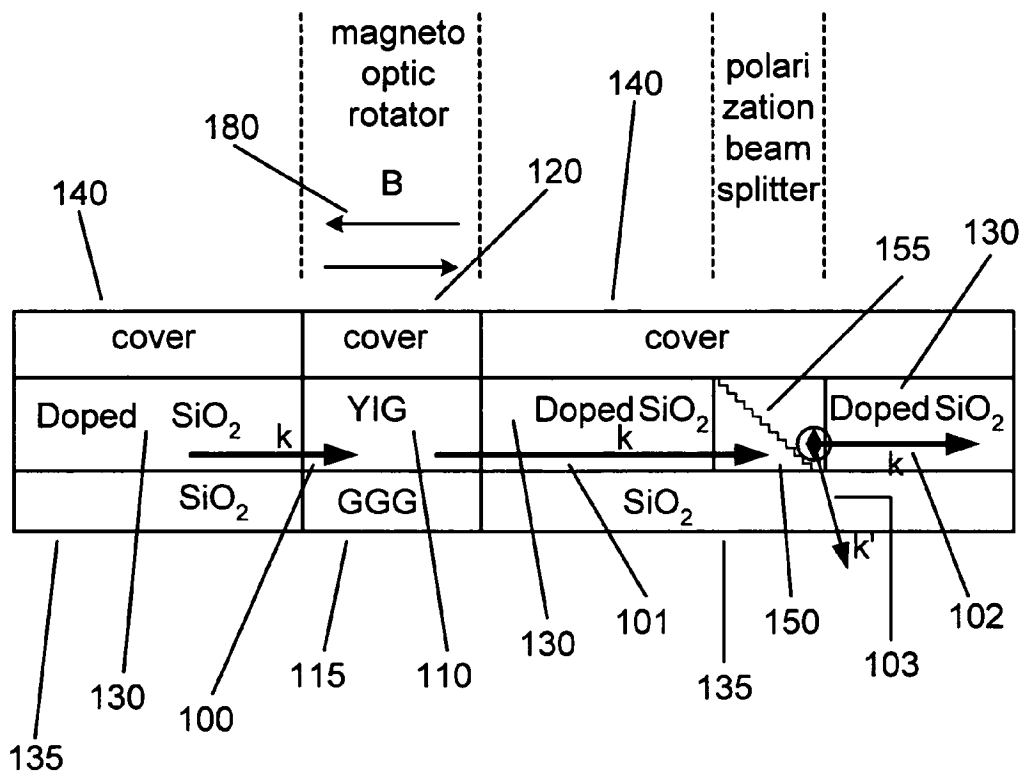

Fig. 1

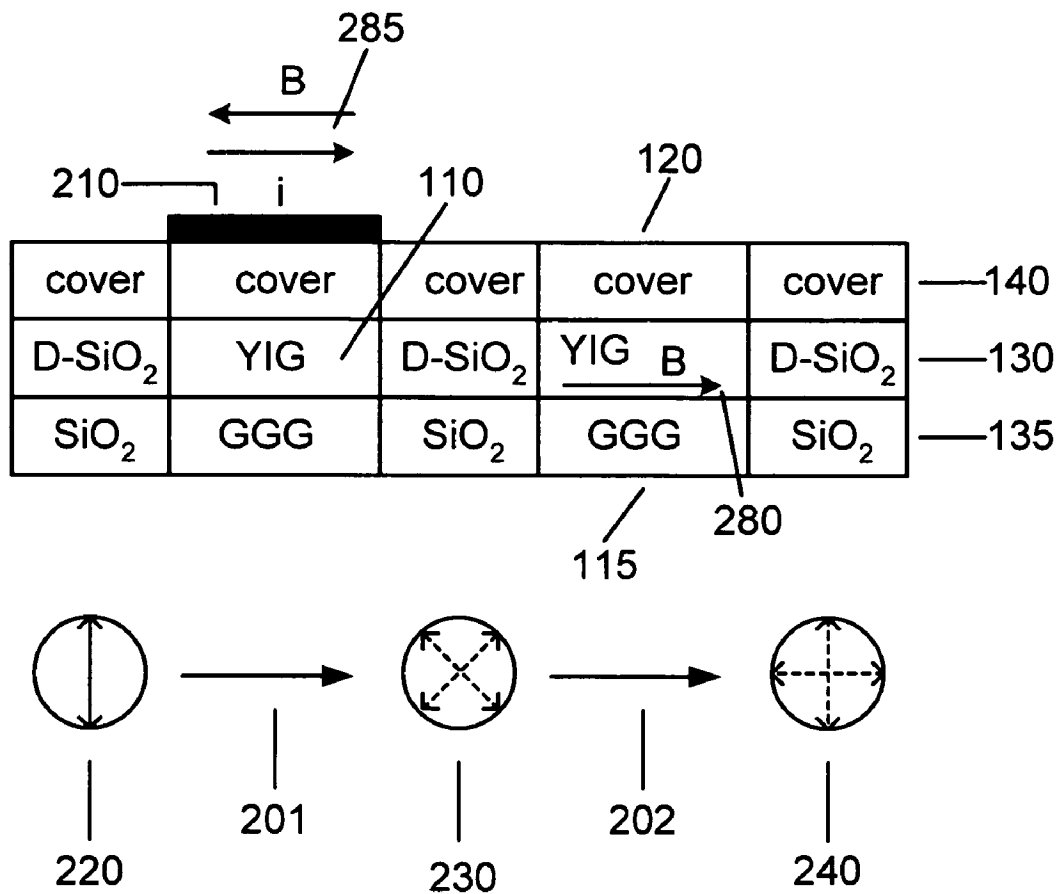

Fig. 2

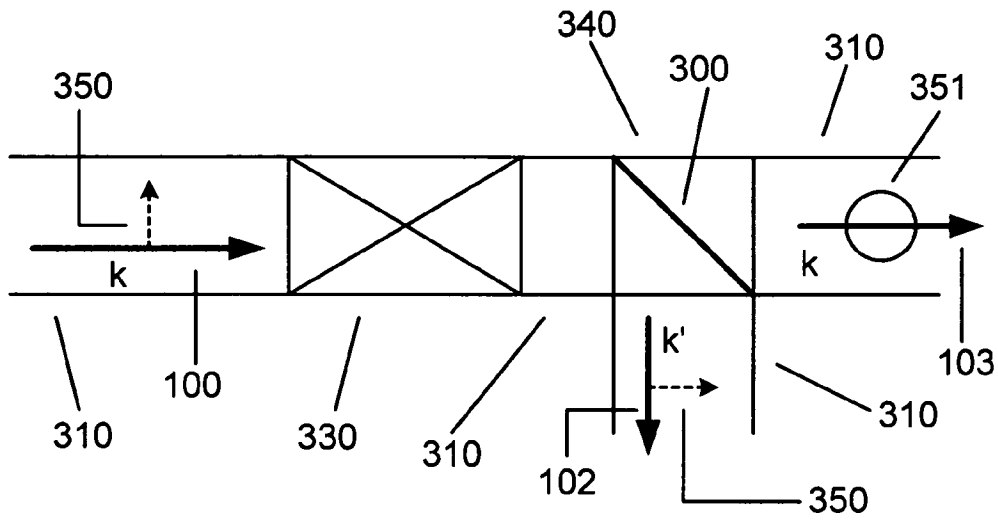

Fig. 3A

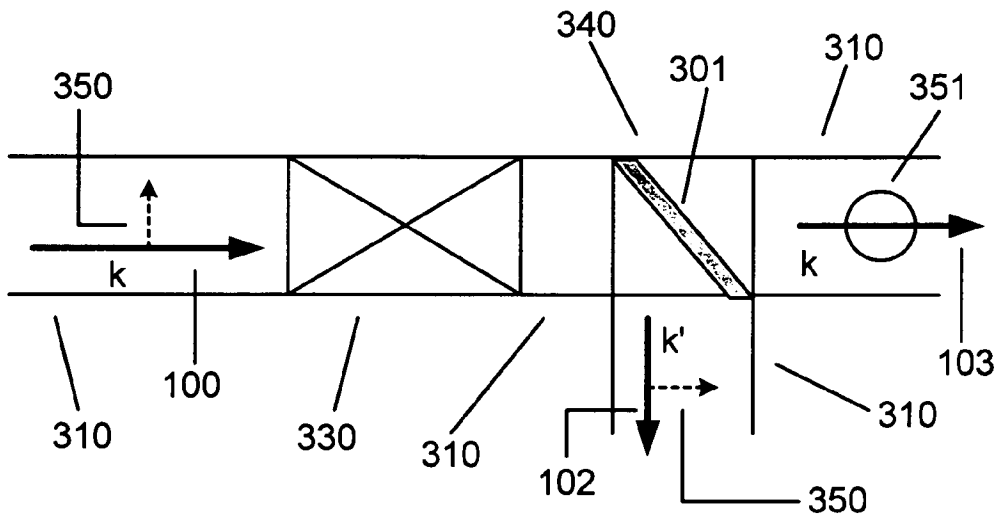

Fig. 3B

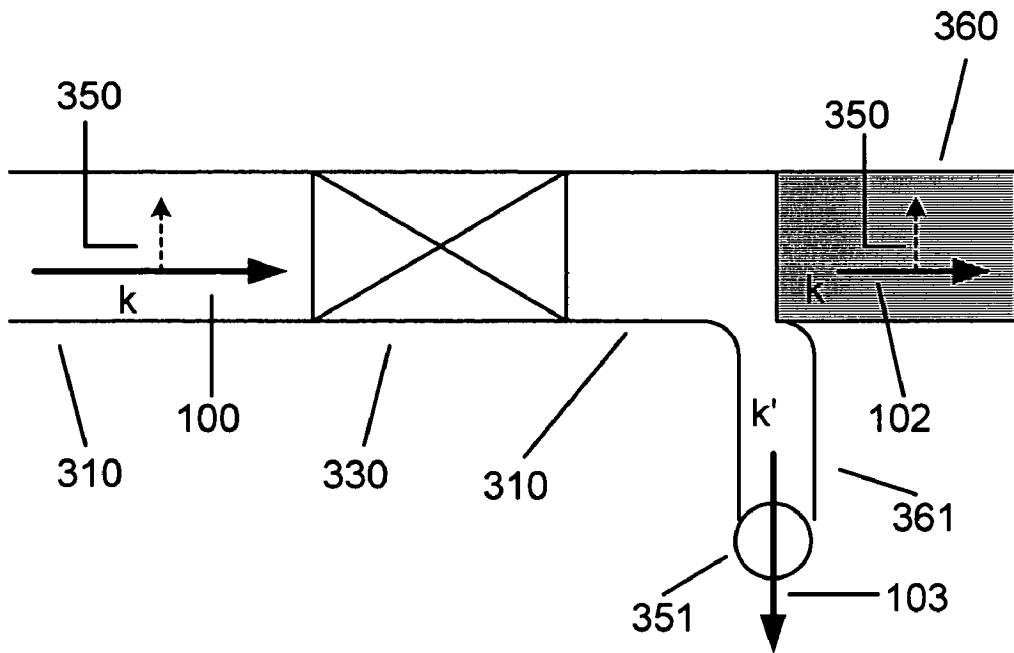

Fig. 3C

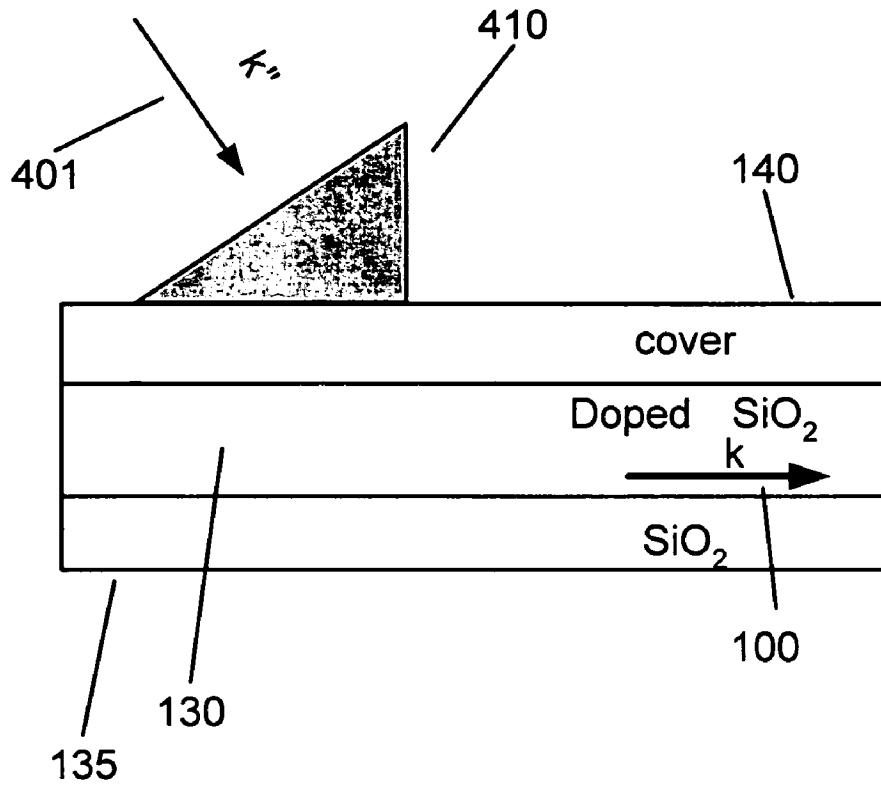

Fig. 4A

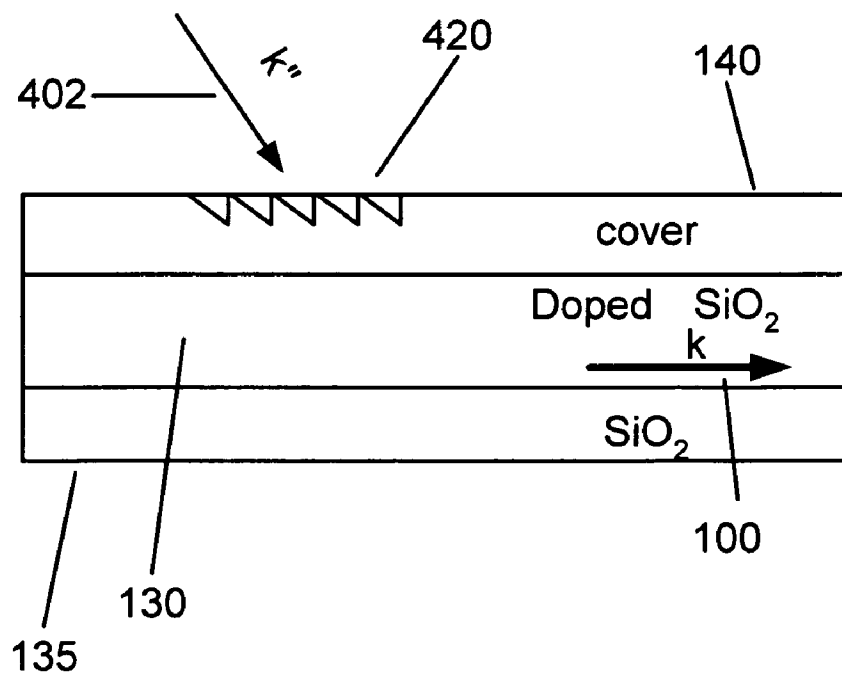

Fig. 4B

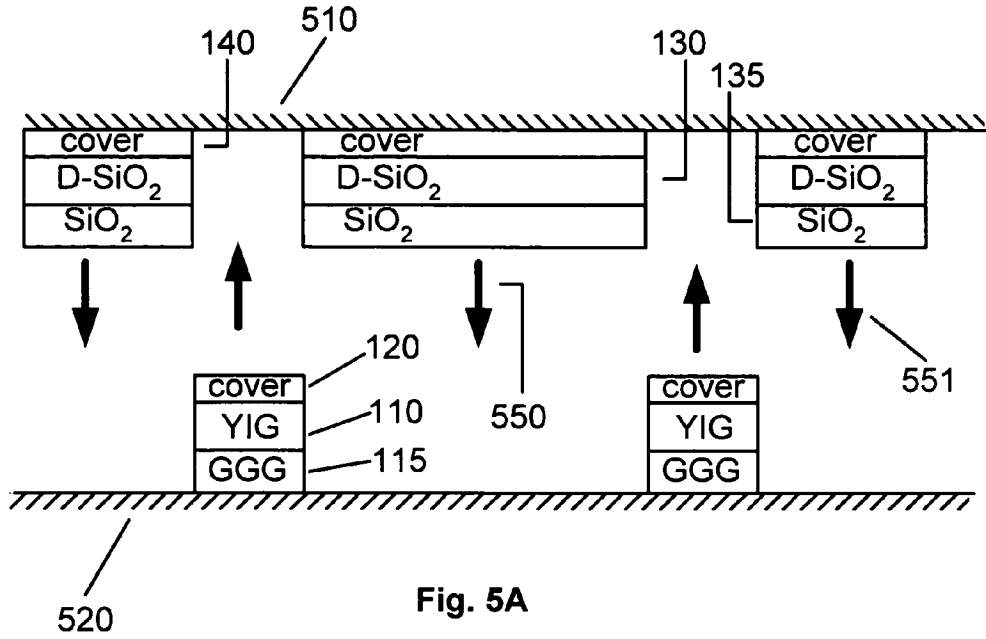

Fig. 5A

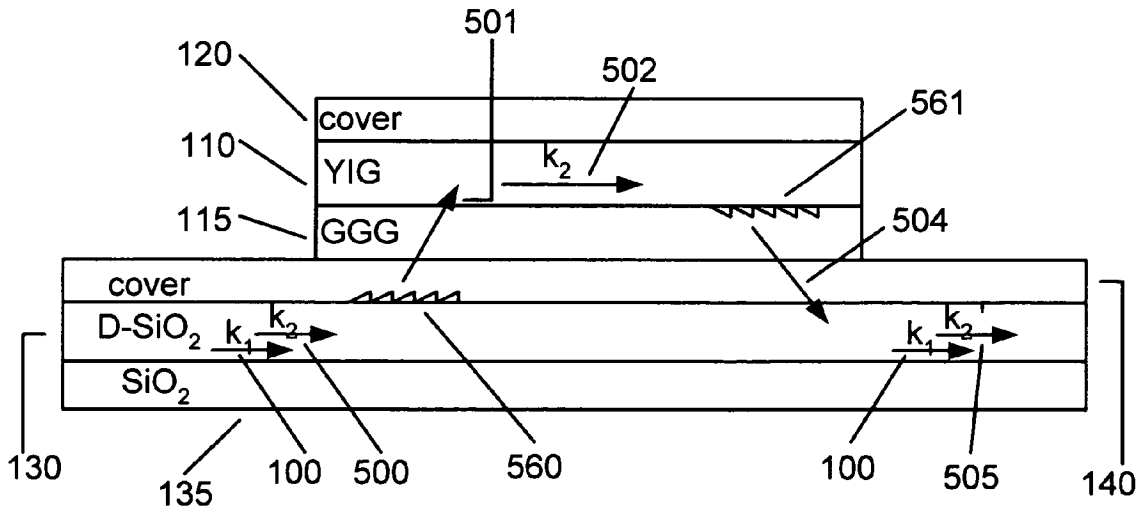

Fig. 5B

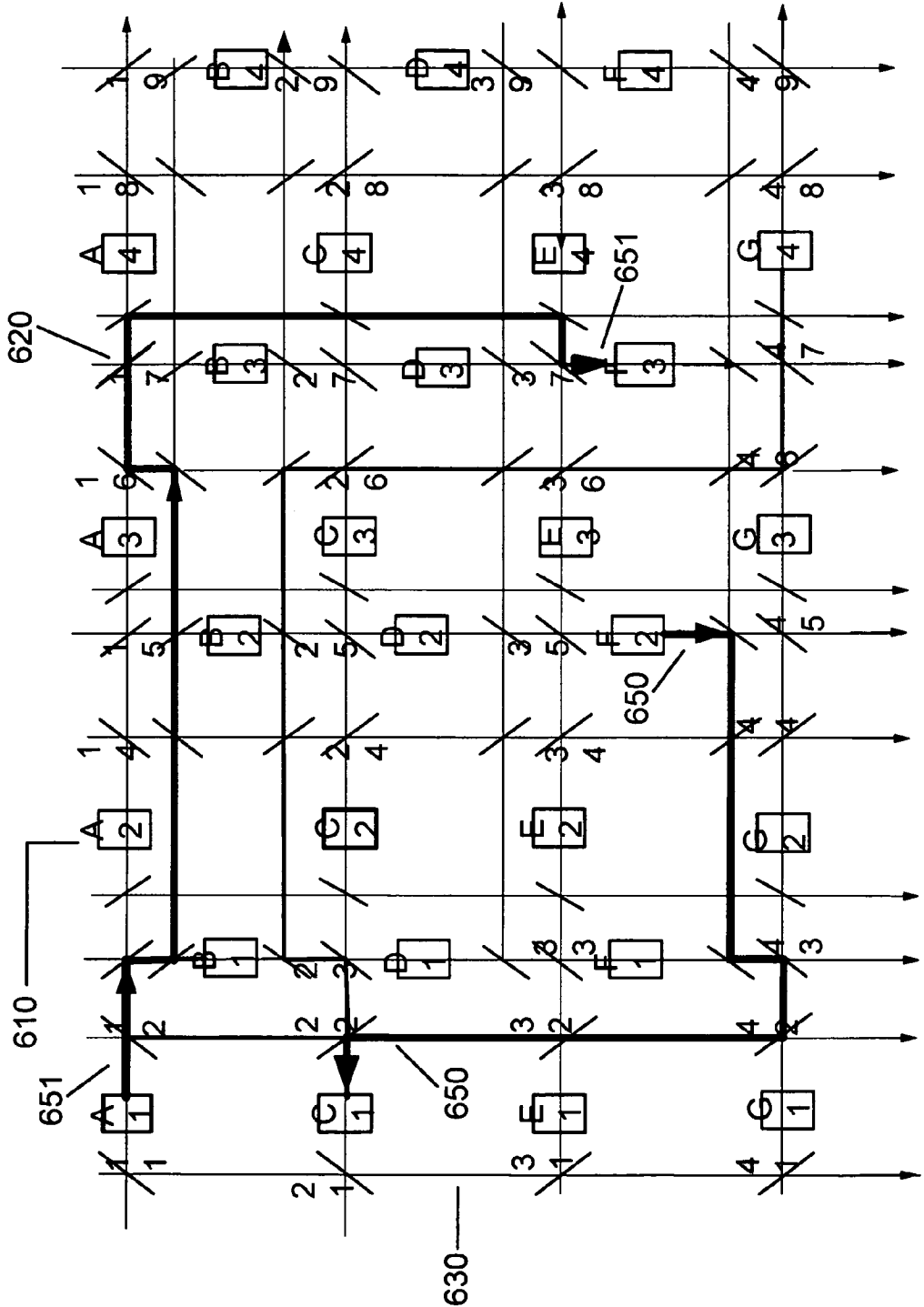

Fig. 6



**MAGNETO-OPTICAL SWITCHING  
BACKPLANE FOR PROCESSOR  
INTERCONNECTION**

**CROSS REFERENCE TO A RELATED  
APPLICATION**

This application is a division of application Ser. No. 10/073,450, filed Feb. 11, 2002, now U.S. Pat. No. 6,816,637.

**FIELD OF THE INVENTION**

This invention relates to a system, and a method, for using an optical backplane to provide ultra high frequency optical interconnections amongst microprocessors. The backplane is comprised of an optical waveguide network and magneto-optical routers.

**BACKGROUND OF THE INVENTION**

The speed of computing devices, such as electronic processors, has been steadily increasing. Processing speed is accompanied by a need for rapid communication amongst processing units. The communication bandwidth requirements of microprocessors (the words processing unit and microprocessor will be used interchangeably) are roughly proportional with speed, and chip cycle times are reaching into the GHz domain. The central computing complexes of large computers comprise of many individual microprocessors, packaged into multi chip modules (MCM), combining their individual performance in a fashion that is transparent to end user. This is only possible if the individual microprocessor chips communicate with each other at sufficiently high bandwidth. Another arena where processor unit to processor unit communication is of concern is the massively parallel computing approach. In such computers hundreds, or thousands, of individual processors, each possibly comprising of several microprocessors, have to be all interconnected at high speeds. A major packaging challenge of computing systems always has been the communication infrastructure, the so called wiring backplane of sufficient bandwidth. The way this is presently done is to have sufficient number of metal wiring in the backplane, connecting the processors to one another. However, as data rates increase metal interconnects between chips, or between multi chip modules, are reaching their limits. Communication between processor chips is starting to be a performance bottleneck. Metal interconnects suffer from loss, cross talk, excessive power requirements, all limiting the maximum achievable bandwidth. As a result of such difficulties optical interconnections are now being seriously considered to take the place of metal wiring.

Optical interconnects have the distinct advantage of almost limitless bandwidth, no cross talk, and low loss. However, the actualization of a purely optical backplane hitherto faced formidable obstacles. There are problems with the integration of lasers, detectors, and waveguides into necessarily small spaces afforded in microprocessor technology. There is also the problem of how to direct light pulses along an optical network at GHz speeds. Then, there is the problem of process integration, namely the difficulty of the processing technology needed to incorporate lasers, detectors, and waveguides into a CMOS technology framework.

**SUMMARY OF THE INVENTION**

The object of this invention is an optical backplane and methods of its use in an electronic processing system. Such a processing system comprises of a large number of microprocessors, with the backplane providing connections amongst the processing units. The processing system can be a single processor in a multi chip embodiment, in which case the processing units are individual chips, or the processing system itself can be a multi processor, in which case the individual processing units again can be chips, or can alternatively be MCMs. Or, one can have combinations of these, depending on the particulars of a system, as one skilled in the art would observe.

It is a further object of the invention to use thin film technology for creating the optical backplane, such a technology being similar and compatible to that used in CMOS technology, whereby such an optical backplane can be integrated with CMOS technology.

It is yet a further object of the invention to provide for routers in such an optical network. These routers are based on magneto-optical polarization rotator and polarization beam splitter combinations.

It is yet a further object of the invention to provide for the whole optical interconnection network, based on planar, ridge, or cylindrical waveguides. Such waveguide types are well known in the appropriate arts. Also, for providing apparatus and method for controlling the routers in such an optical network. The routers allow establishing of communication amongst processing units at a speed commensurate with the bandwidth requirements. Communication amongst processing units can mean interconnecting any two unit, or to allow for a broadcasting mode, where one processing unit simultaneously transfers data to more than one other unit, or possibly to all of the other units.

The light in the network originates when electrical signals from each microprocessor drive an array of lasers, preferably Vertical Cavity Surface Emitting Lasers (VCSEL'S). Laser light is polarized, and when such light is steered into the waveguide network through the optical devices that operationally connect the processing units to the network, it enters the waveguides in a polarized state. The operation of the optical routers is based on the fact the light in the network is polarized. There are several ways, based on polarization beam splitters, to direct light into differing optical paths depending on the polarization angle of the light. If such a polarization beam splitter is preceded by an optical element which is capable to controllably set the polarization angle, one has achieved an optical router which is part of an optical waveguide network. In the preferred embodiment such an optical element, which controllably sets the polarization angle, is a magneto optic rotator (MOR). In a MOR the waveguiding layer has magnetic properties, and depending on its magnetization state it rotates the polarization angle of the guided light. In a preferred embodiment such a magneto-optically active layer comprises of Yttrium Iron Garnet (YIG).

When the polarized light passes through a YIG waveguide segment, the polarization of the incident light can be converted from TE to TM mode (horizontal to vertical polarization), or vice versa, depending on the magnetization within the YIG. In a preferred embodiment this mode conversion is done in two steps, using two sections of YIG material. In the first step the incident polarization is rotated by +45° or -45°. A second section of YIG waveguide has its magnetization permanently aligned parallel to the direction of light propagation and gives a constant +45° of rotation to

the incident light, which has already been rotated by  $+45^\circ$  or  $-45^\circ$ . This then gives a final angle of rotation of  $90^\circ$  or  $0^\circ$ , depending on the choice made in controlling the magnetic field in the first section. One skilled in the art will observe that the operation of the routing scheme is not in need of polarization rotation angles which are exactly of the desired values. There is some latitude of having the polarization rotations accomplished to within a few percent of the exact desired values.

#### BRIEF DESCRIPTION OF THE DRAWINGS

These and other features of the present invention will become apparent from the accompanying detailed description and drawings.

FIG. 1. Shows elements of a router for polarized light.

FIG. 2. Shows two section of a magneto optic rotator as part of an optical network.

FIG. 3. Schematically shows routers for polarized light with various embodiments of polarization beam splitters.

FIG. 4. Schematically shows optical devices for operationally connecting processing units to the waveguide network.

FIG. 5. Shows various embodiments for integrating a magneto optic rotator with a waveguide.

FIG. 6. Schematically shows part of an optical backplane interconnecting processing units of an electronic processor.

#### DETAILED DESCRIPTION OF THE INVENTION

FIG. 1 shows elements of a router for polarized light. The router comprise of two parts, a magneto optic rotator (MOR) followed by a polarization beam splitter (PBS). In one embodiment these two parts of the router are seamlessly integrated into an optical waveguide. FIG. 1 shows a sandwich structure for both the router and for the shown pieces of the waveguide network. The waveguide network of the optical backplane is based on a  $\text{SiO}_2$ , or alternatively a polymer, waveguide structure. In one embodiment an undoped  $\text{SiO}_2$  optical layer **135** of an index of refraction ( $n_s$ ) is interfacing with a doped  $\text{SiO}_2$  layer **130**. Due to the doping, the doped  $\text{SiO}_2$  has an index of refraction, ( $n_f$ ) approximately equal to 1.45. The waveguide typically needs a doped  $\text{SiO}_2$  which interfaces, that is, it is deposited on the top, or below, of an undoped  $\text{SiO}_2$ . The requirement of this undoped  $\text{SiO}_2$  layer is for it to have a lower refractive index than the doped  $\text{SiO}_2$  layer. In the embodiment of a sandwich structure, the doped  $\text{SiO}_2$  layer **130** being disposed between the undoped  $\text{SiO}_2$  layer **135** and a third optical layer, or cover layer **140**, which has a refractive index ( $n_c$ ). The doped  $\text{SiO}_2$  layer **130** is guiding the polarized light because the refraction indexes are such that  $n_c < n_f > n_s$ . The cover layer **140** in a preferred embodiment is another layer of undoped  $\text{SiO}_2$ , but it can be made by many other optical materials as long as  $n_c < n_f$ . The cover layer **140** can be omitted, with air (or vacuum) taking up the appropriate optical role.

The MOR is also shown in a sandwich structure embodiment. A magneto-optically active layer **110**, in a preferred embodiment a YIG layer, being disposed between a gadolinium gallium garnet (GGG) layer **115** and a cover layer **120**. The cover layer **120** in a preferred embodiment is another layer of GGG, but it can be made by many other optical materials as long as it has a refractive index below that of YIG. The cover layer **120** can be omitted, with air (or vacuum) taking up the appropriate optical role. The MOR

has a magneto-optically active layer which interfaces, that is, it is deposited on the top, or below, of an additional optical layer. The requirement of this additional optical layer is for it to have a lower refractive index than the magneto-optically active layer. The cover layer **120** is a third optical layer making up the sandwich structure together with the magneto-optically active layer **110** and the additional optical layer **115**. In case of a sandwich structure the two layers between which the magneto-optically active layer is being disposed are two other optical layers. In order for the light to be guided in the magneto-optically active layer, the these two other optical layers have lower refractive indexes than the magneto-optically active layer. The polarized light is guided in the YIG layer **110**, which receives the light **k 100**, from the doped  $\text{SiO}_2$  layer **130**, and transmits the light **k 101** back to the doped  $\text{SiO}_2$  layer **130**. The index  $k$  being a light propagation wave vector indicating propagation and wavelength.

The YIG layer **110** can be grown by liquid phase epitaxy (LPE) or epitaxial sputter deposition on GGG layers. The index of refraction of GGG layer **115** is approximately 1.94, while that of the YIG layer approximately 2.18.

An external variable magnetic field **180** is applied to the MOR. The external magnetic field **180** lines up the magnetization of the YIG layer **110**, and according to the direction of this lineup and the strength of the field the polarization angle of the light **100**, is either rotated by approximately  $90^\circ$ , or it is left approximately intact. Accordingly light **101** might have the opposite (horizontal vs vertical, or vice versa), polarization compared to light **100**. Light **101** next arrives to a PBS **150**. The shown PBS is of the variety which is constructed into the optical waveguide network. The light guided by layer **130** strikes the PBS **150** which in FIG. 1 is a vertical polarization grating **155** etched into the waveguide network. The etching would be perpendicular into the doped  $\text{SiO}_2$  waveguide and then would be filled with a conducting material such as copper. A polarization grating, such as **155**, and its operation is known in the art. (See for instance, Wang and Shablisky, J. Vac. Science and Technology, Vol 17B, No. 6, p2957.)

The grating **155** transmits the light **101** continuing in the straight direction  $k$  **102**, if light **101** had one (horizontal or vertical) polarization angle, or deflects it into a side branch of the optical network in direction  $k'$  **103**, if light **101** had the perpendicular polarization angle (vertical or horizontal). The polarization angle of light **101** was determined by magnetic field **180**, thus by controlling field **180** one can choose the path that the light takes in the network.

FIG. 2. shows two section of a MOR as part of an optical network, a preferred embodiment. In a first section, where the light enters first, the magnetization of the YIG layer **110** is determined by a variable magnetic field **B 285**. The field is created by a current "i" flowing in a metallic strip **210**, where the metallic strip substantially covers this first section of the MOR. Substantially covering this first section of the MOR means such a positioning that the magnetic field generated by the current flowing in the strip controls the magnetization of the magneto-optically active layer. Typically a magnetic field of 1 gauss is needed in order to switch the magnetization in the YIG, such a field can be generated with a current of less than 125 mA, allowing switching of magnetization at multi GHz frequencies. In this first section the magnetic field **B 285** is selectively switched between two modes. In these two modes the magnetic field is equal in magnitude but opposite in direction. The result is that the polarization angle depending on the choice of the direction of the current will be rotated by either  $+45^\circ$  or  $-45^\circ$ . This is

5

illustrated at the bottom part of FIG. 2. Suppose the light arrives with a vertical polarization **220**. After passing through the first section **201**, it will be in a + or  $-45^\circ$  polarization state **230**. In the second section **202** there is no external magnetic field applied, rather a permanent magnetization prevails **280** in the YIG. This second section **202** is at a sufficient distance from the first section **201**, or it is shielded by other methods, that the variable magnetic field **285** of section **201** does not perturb the permanent magnetization of section **202**. Upon the light passing through the second MOR section the polarization angle is always rotated by  $+45^\circ$ . The net result is that upon leaving the MOR, having crossed both sections, the polarization angle of the light, depending on the outside choice of selecting the right current in strip **210**, either stayed in the original vertical state, or it has been turned by  $90^\circ$ , **240**.

FIG. 3. schematically shows routers for polarized light with various embodiments of polarization beam splitters. The figure roughly depicts the waveguides from a top view.

In FIG. 3A a Brewster angle PBS **300** is shown. Such a Brewster angle beam splitter can be fabricated by etching a trench at Brewster's angle into the doped region of the  $\text{SiO}_2$  waveguide **340**. This surface is then coated with Magnesium Fluoride (MgF) stacks of  $\frac{1}{4}$  wavelength thickness to enhance the polarization selectivity. The MgF layers can be deposited by physical vapor deposition. The rest of the trench can be filled with a low index,  $\sim 1$ , material or air.

In the shown case light **100** with a certain polarization **350** is traveling in the waveguide network **310**. In the **330** MOR the polarization angle may be rotated to the opposite state (horizontal vs vertical, or vice versa). Upon arriving to the splitter region **340**, with the Brewster angle splitter **300**, the light is transmitted **103** if its polarization state has been changed **351**, or it is deflected **102** if its polarization state remained the same **350**. One can adjust the position of the Brewster angle beam splitter to transmit or deflect with opposite polarization than just described. The result in any case is that depending on a polarization rotation which occurred in the MOR **330**, the light is controllably routed.

In FIG. 3B a birefringent prism **301** built into the waveguide network is shown. Such a birefringent material prism can be quartz or calcite built into the doped  $\text{SiO}_2$ . This thin film Glan-Thompson type polarizer can be fabricated by depositing doped  $\text{SiO}_2$  on a quartz substrate, epitaxially recrystallize this amorphous  $\text{SiO}_2$  layer with Cs ion irradiation and annealing. (See for instance: F. Roccaforte and S. Dhar, Appl. Phys. Lett. Vol. 75, No 19. p 2903, 1999.) This thin film of doped crystallographically oriented quartz can then be patterned into the Glan-Thompson type polarizer, and mated to the rest of the waveguide structure **340**.

In the shown case light **100** with a certain polarization **350** is traveling in the waveguide network **310**. In the **330** MOR the polarization angle may be rotated to the opposite state. Upon arriving to the splitter region **340**, with the birefringent prism **301**, the light is transmitted **103** if its polarization state has been changed **351**, or it is deflected **102** if its polarization state remained the same **350**. The birefringent prism **301** can be built into the waveguide to transmit, or deflect, with the opposite polarization than was just described. The result in any case is that depending on a polarization rotation which occurred in the MOR **330**, the light is controllably routed.

The Brewster mirror splitter **300**, the birefringent prism **301**, and the polarization grating splitter **155**, shown in FIG. 1, are PBS embodiments of optical elements constructed into the optical waveguide network. FIG. 3C show a PBS embodiment which functions based on a waveguiding property.

6

In FIG. 3C the PBS is having asymmetric waveguide output arms **360** and **361**. Each of the waveguide output arm is capable of propagating light only with one predetermined polarization angle. This is done by fabricating the output of the directional coupler with one arm **360** designed such that its vertical dimension (thickness) is small enough to be below the cut off condition for the vertical mode, and thus only guides the horizontal **350** mode. Similarly, the other arm **361** is designed such the horizontal dimension cannot support the horizontal mode and only supports the vertical mode **351**. Light **100** with a horizontal polarization **350** is traveling in the waveguide network **310**. In the **330** MOR the polarization angle may be rotated to the opposite state (horizontal vs vertical, or vice versa). Upon arriving to the splitter region, in the shown case the light is transmitted **102** if its polarization state is still horizontal **350**, or it is deflected **103** if its polarization state has been rotated **351**. One can of course change the directions of the two arms. The result in any case is that depending on a polarization rotation which occurred in the MOR **330**, the light is controllably routed. These waveguide output arms have an appropriate length to accomplish their purpose of propagating only one type of polarization. Past this appropriate length they are fabricated to revert back to the normal shape of the waveguides.

FIG. 4. schematically shows optical devices for operationally connecting processing units to the waveguide network. The term operationally connecting means to establish an optical connection between the electronics of the processor unit and the waveguide network. Electrical signals from each microprocessor are used to drive an array of lasers, preferably Vertical Cavity Surface Emitting Lasers (VCSEL'S), that can be fabricated on a common substrate with the processor units. VCSEL's are preferred because of their high density and thus the possibility to be integrated into CMOS technology. Light from the microprocessors driven lasers typically goes through various beam shaping optics, well known in the optical sciences. Following the beam shaping, the light has to enter the waveguide network. FIG. 4A shows an embodiment where this is accomplished with prism coupling optics. Light from the beam shaping optics **401** is directed k" to prism **410**, which couples the light for guidance into layer **130** of the waveguide network. An array of rutile prisms **410** can be fabricated commonly with the laser array and beam shaping optics. These would then be used to prism-couple light into the waveguide that is part of the optical backplane. An alternate preferred embodiment of coupling light into the waveguide is to use grating coupling optics instead of prism coupling optics. Light from the beam shaping optics **402** is directed k" to grating **420**, which couples the light for guidance into layer **130** of the waveguide network. This gratings coupling optics **420** can be etched directly into the waveguides.

FIG. 5. shows various embodiments for integrating a magneto optic rotator with a waveguide. FIG. 5A shows fabrication of a seamlessly meshed coplanar waveguide configuration. The YIG waveguide structure **110** can be grown, for instance, by LPE, or epitaxial sputter deposition on GGG substrates **115**. While the GGG itself rests on a substrate **520**, which can be removed if needed upon completion of the whole structure. A cover layer **120**, itself maybe made of GGG, can also be deposited, but it is not necessarily needed.

Once the YIG structures are grown they are patterned by etching, or by lithography into properly spaced approximately 3mm sections that would mate **550** and **551** to the  $\text{SiO}_2$  structures. The  $\text{SiO}_2$ , or possibly polymer, waveguide network itself is deposited or grown on a substrate **510**,

which can be removed if needed upon completion of the whole structure. The SiO<sub>2</sub> waveguide structure can be lithographically patterned to accommodate the sections of YIG waveguides. In this manner the network of optical waveguides, including routers, are seamlessly meshed together into a coplanar configuration.

FIG. 5B shows an embodiment where the MOR waveguide is external to the network of optical waveguides, and where grating coupling is used to steer the light between the waveguides. This embodiment is preferred when the optical waveguides contain a number of wavelengths, making use of wavelength division multiplexing to increase bandwidth. The figure shows only two wavelengths, 100 and 500, but the embodiment can deal with many more. The aggregate number of external MOR sections increases proportionally with the number of the wavelengths. For instance, for two different wavelengths one needs two external MOR sections. Although FIG. 5B shows the operation of only a single external MOR, the operation of multiple ones is exactly the same. The etched grating 560 matches one of the light wavelengths 500, and this light is switched out into the MOR. Here at the system's choice the polarization angle of light 501 is rotated, or not rotated, propagating now as light 502. After the rotating sections a grating etched into the MOR 561 steers light 502 toward the waveguide network. Returning to the waveguide network and propagating as light 505, it has the same wavelength as earlier 500, except that its polarization angle might have been changed. In the meantime light 100 propagates uninterrupted, since its wavelength is not matched to grating 560. Routing of light 100 occurs at another section of the waveguide network, where another external MOR is coupled to the waveguide with a grating that matches the wavelength of light 100.

FIG. 6. schematically shows part of an optical backplane interconnecting processing units of an electronic processor. This backplane provides optical interconnections amongst processing units of the electronic processor, which comprises of all such processing units. Processing units 610, labeled from A1 to F4 are interconnected with the waveguides of the backplane. At vertexes of the network reside the magneto optic routers 620, labeled from 11 to 49. The network can establish a connection path between any two processing units. FIG. 6 shows two such example paths. Path 651 guides optical signals from processing unit A1 to processing unit F3, while path 650 guides optical signals from processing unit F2 to processing unit C1. Such paths are formed upon the arising of a communication need by setting the state of the appropriate MOR routers. When the communication has occurred, the routers and waveguides of the former path are ready to be part of a new path. The method of directing such communication amongst said processing units should keep track at any given time of a state of said optical backplane, should accept requests for communication from one or more of the processing units, should identify available optical paths, should connect the processing units in need of communication, should set the conditions of the optical routers along the chosen path, and should direct the processing units in need of communication to execute the communication. The communication in the optical network can be point to point, or in a broadcasting mode, where one processing unit simultaneously transfers data to more than one other unit, or possibly to all of the other units. The backplane is efficient in area density. Counting a processing unit operationally connected to the network, a router, and a PBS as one element, one can roughly place as many as 100 elements on a 10 cm<sup>2</sup> surface.

Many modifications and variations of the present invention are possible in light of the above teachings, and could be apparent for those skilled in the art. The scope of the invention is defined by the appended claims.

We claim:

1. A method for directing a communication amongst processing units, comprising:

providing an optical backplane interconnecting said processing units, wherein said optical backplane comprises a network of optical waveguides for guiding a polarized light of a plurality of wavelengths, and magneto optic rotator (MOR) routers, wherein said MOR routers are grating connected to said network of optical waveguides, and wherein each of said plurality of wavelengths is individually grating coupled to said MOR routers;

keeping track of a state of said optical backplane;

accepting requests for said communication from one or more of said processing units;

identifying one or more available optical paths on said optical backplane, wherein said available optical paths are connecting processing units in need of communication;

setting conditions of said optical routers along said one or more available optical paths,

wherein said conditions allow for transmitting light along said one or more available optical paths; and

directing said processing units in need of communication to execute said communication.

2. The method of claim 1, further comprising the step of directing said processing units to execute a point to point communication.

3. The method of claim 1, further comprising the step of directing said processing units to execute a broadcasting mode communication.

4. A computer data signal embodied in a carrier wave encoding a computer program of instructions for executing a computer process for directing a communication between processing units, comprising:

keeping track of a state of an optical backplane, wherein said optical backplane is interconnecting said processing units, and wherein said optical backplane comprises a network of optical waveguides for guiding a polarized light of a plurality of wavelengths, and magneto optic rotator (MOR) routers, wherein said MOR routers are grating connected to said network of optical waveguides, and wherein each of said plurality of wavelengths is individually grating coupled to said MOR routers;

accepting requests for said communication from one or more of said processing units;

identifying one or more available optical paths on said optical backplane, wherein said available optical paths are connecting processing units in need of communication;

setting conditions of optical routers along said one or more available optical paths,

wherein said conditions allow for transmitting light along said one or more available optical paths; and

directing said processing units in need of communication to execute said communication.

5. The computer data signal of claim 4, wherein said carrier wave is an optical wave.